

EIA -Based VectorPak™ Subrack Systems

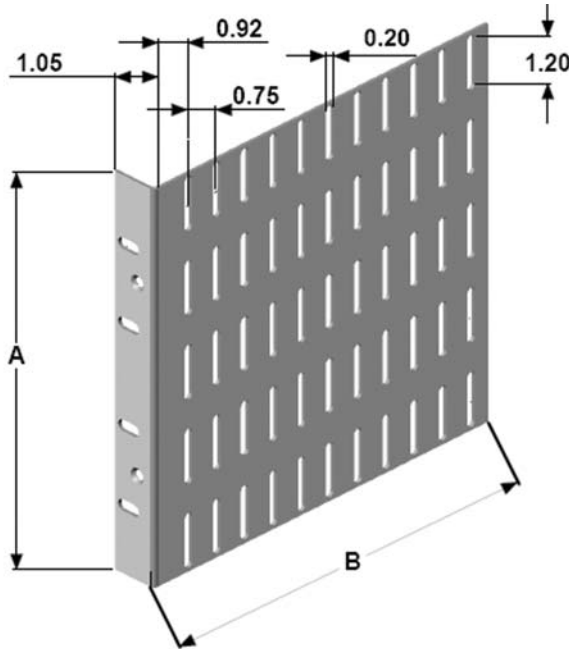

Rack Accessories



“P” Type Side Panel

Material: 0.080" aluminum with clear irridite finish

Part No.	Overall Height A	Depth B	Vector Handle	Accepts Max Card Height	Rack Units (H)
SW52P89/90	5.23"	9.0"	HA12	4.5"	3U
SW52P119/90	5.23"	12.0"	HA12	4.5"	3U
SW52P156/90	5.23"	15.75"	HA12	4.5"	3U
SW69P119/90	6.98"	12.0"	HA13	6.25"	4U
SW69P156/90	6.98"	15.75"	HA13	6.25"	4U
SW87P119/90	8.73"	12.0"	HA12	8.0"	5U
SW87P156/90	8.73"	15.75"	HA12	8.0"	5U
SW104P156/90	10.47"	15.75"	HA12	9.75"	6U
SW122P156/90	11.975"	15.75"	HA12	11.5"	7U
SW122P202/90	11.975"	20.25"	HA12	17.5"	7U

T-Struts Part Mounting Hardware

Metal or plastic screw down card guides attach with SC4-27/25 flat head screw and NT4-7PA square nut. Square nuts slide into T-strut slots and anchor 4-40 screws for mounting parts. Supplied in quantities of 25 ea.

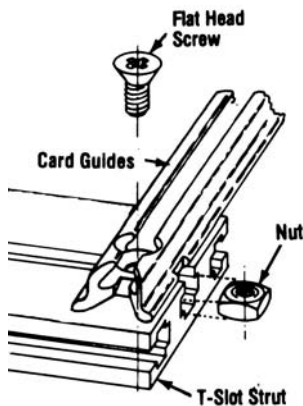

Part No.	Description	Size	Pkg Qty
NT4-7PA	Square nut	4-40	25
SC4-27/25	100o flat head screw	4-40 X 1/4"	25

Modules or Front Panel Mounting Hardware

SC 10-2A Thumb screws and SC10-3A jack screws (supplied with EFP modules, Cardmount modules and front assemblies to T-struts. SP09-2 spacers are used as standoffs for mounting modules to 1" T-struts (1.79" struts are standard with module subracks.)

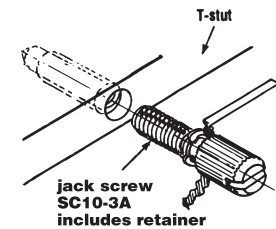
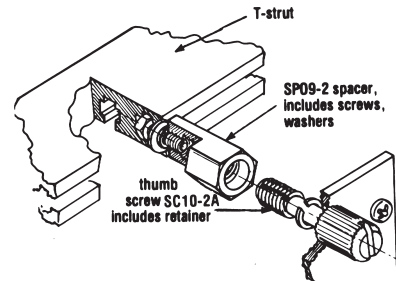

Part No.	Description	Pkg Qty
BR64#	Right angle bracket and two mounting screws	1
SP09-2	Hex spacer for module mounting, includes hardware	12
SC10-2A	Thumb screw fully threaded for direct attachment of panels	12
SC10-3A	Jack screw for mounting modules to T-struts with jacking action	12
HD34	Connector mounting hardware, includes SC4-28 screws, NT4-2# nuts and lockwashers	42ea.
HD52	4-40 nut for connector mounting	42ea.
SC4-28	4-40 hex head screws, 3/4" long, Lock washer	24
	4-40 hex head screw, 1/2" long for connector mounting	

EIA Subracks

